

# SWRO Series 50 Hz

Seawater Desalination Machines  
45,000 ppm NaCl  
100-300 m<sup>3</sup>/day (20-60 gpm)

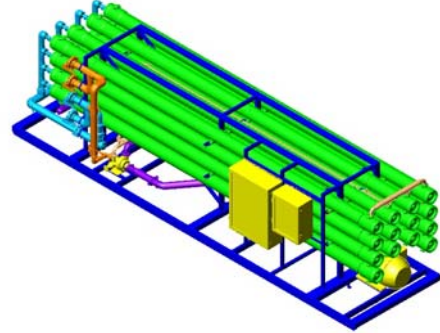

## Basic Features (BAS)

- GE Fanuc Quick Panel 6"  
6-inch color display  
Primarily text operating screens  
Touchscreen controls
- GE Fanuc Micro VersaMax  
Communication: RS232/DH485  
Analog output: 6 points
- 4-20 mA instruments displayed on instrument center
- Variable frequency drive (VFD) for high pressure pump
- Stand alone master control enclosure, skid mounted local control enclosure with terminal strips

## Premium Features (PRE)

- GE Fanuc QuickPanel 12"  
12-inch color display  
Text and pictorial operating screens  
Touchscreen controls
- GE Fanuc VersaMax  
Communication: RS232/DH485/Ethernet  
Analog output: 4 points
- 4-20 mA instruments on PanelView
- Primary and final pressure transmitters
- Variable frequency drive (VFD) for high pressure pump
- Automated valves and control for full permeate flush upon shut down
- Stand alone master control enclosure, skid mounted local control enclosure with remote I/O

## Instrumentation

Flow Meters	Permeate, concentrate
Conductivity	Permeate
pH	Feed
Pressure	Pre-filter, post-filter, primary, final, permeate, concentrate, pump discharge (PRE Feature= Primary, Final transmitter)
Pressure Switch	Feed, permeate, concentrate
Instrument center	Thornton 770 MAX

## Options Available

- Allen Bradley control system
- Multi-Media filters
- Clean-in-Place (CIP) units
- Chemical feed systems

## Documentation Included

- Operation and maintenance manual
- Control narrative
- Drawings: piping and instrumentation, electrical and general dimensional

## Operating Parameters

Recovery	35%
Design temp.	25°C (77°F)
Design Feed TDS.	45,000 ppm NaCl
Operating range	2 to 30°C (35 to 85°F)
Minimum inlet pressure	2 Bar (30 psi)



Visit us online at [www.gewater.com](http://www.gewater.com)  
©2004, General Electric Company.  
All rights reserved.

**Global Headquarters**  
Trevose, PA  
+1-215-355-3300

**Americas**  
Watertown, MA  
+1-617-926-2500

**Europe/Middle East/Africa**  
Heverlee, Belgium  
+32-16-40-20-00

**Asia/Pacific**  
Shanghai, China  
+86-21-5298-4573

\*Trademark of General Electric Company; may be registered in one or more countries.

CH0000EN 0411

## Materials of Construction

High-pressure piping	Sch. 10, Duplex 2205 Stainless Steel
Low-pressure piping	Sch. 80, PVC
Frame	Painted carbon steel
Local Enclosure	FRP, NEMA 4X
Main Enclosure	Painted carbon steel, NEMA 4
VFD Enclosure	Painted carbon steel, NEMA 4
Clamps/fittings	Zinc-plated

## Membrane Elements and Housings

Style	Spiral-wound elements
Membrane type	TFC HR (Polyamide)
Element Area	37 m <sup>2</sup>
Average membrane flux	13.5-17 l/mh
Housing material	FRP, 80 Bar (1200 psi)
Housing closure type	Ring and plate style closure

## Cartridge Filtration

Housing material	GRP (glass reinforced plastic)
Cartridge filter	5-micron nominal, ROsave.Z*s

## GE Infrastructure Water & Process Technologies SWRO Models

MODEL	SWRO-8	SWRO-16	SWRO-24
Permeate rate:	100 m <sup>3</sup> /day (18.3 gpm)	200 m <sup>3</sup> /day (36.7 gpm)	300 m <sup>3</sup> /day (55.0 gpm)
Concentrate Rate:	185 m <sup>3</sup> /day (33.9 gpm)	371 m <sup>3</sup> /day (68.1 gpm)	557 m <sup>3</sup> /day (102.2 gpm)
Feed Rate:	285 m <sup>3</sup> /day (52.3 gpm)	571 m <sup>3</sup> /day (104.8gpm)	857 m <sup>3</sup> /day (157.2 gpm)
Pumps and Motors			
Model:	MSS 1540	MSS 2030	MSS 3030
Manufacturer:	Osmonics/FEDCO®	Osmonics/FEDCO®	Osmonics/FEDCO®
Quantity:	1	1	1
Motor HP and type:	29.9 kW (40 Hp) TEFC	55.9 kW (75 Hp) TEFC	93.2 kW (125 Hp) TEFC
Design Flow Rate:	12 m <sup>3</sup> /hr (52.8 gpm)	24 m <sup>3</sup> /hr (105.7 gpm)	36 m <sup>3</sup> /hr (158.5 gpm)
Design boost pressure:	47.4 Bar (690 psig)	45.5Bar (660 psig)	42.7 Bar (620 psig)
Energy Recovery Booster			
Model:	HPB 20	HPB 30	HPB 40
Manufacturer:	Osmonics/FEDCO®	Osmonics/FEDCO®	Osmonics/FEDCO®
Quantity:	1	1	1
Design boost pressure:	21.7 Bar (315 psig)	23.4 Bar (340 psig)	26.2 Bar (380 psig)
Membrane Elements and Housings			
Membranes quantity:	8	16	24
Memb. housing style:	4 element long, 4 port	4 element long, 4 port	4 element long, 4 port
Banking Arrangement:	2, parallel	4, parallel	6, parallel
Cartridge Filtration			
Cartridge Filter:	ROZs05-40XK	ROZs05-40XK	ROZs05-40XK
Filter Length:	40" (102 cm)	40" (102 cm)	40" (102 cm)
Filter Quantity:	6 per change out	10 per change out	22 per change out
Installation and Utility Requirements			
Inlet:	2.0" flange	3.0" flange	3.0" flange
Permeate:	1.0" flange	1.5" flange	2.0" flange
Concentrate:	1.5" flange	2.0" flange	3.0" flange
Inlet Water Pressure:	2 Bar, minimum	2 Bar, minimum	2 Bar, minimum
Air Pressure:	7 Bar, oil-free	7 Bar, oil-free	7 Bar, oil-free
Drain to be Sized for:	285 m <sup>3</sup> /day (52.3 gpm)	571 m <sup>3</sup> /day (104.8gpm)	857 m <sup>3</sup> /day (157.2 gpm)
Power:	220/380 VAC, 3-phase, 50Hz	220/380 VAC, 3-phase, 50Hz	220/380 VAC, 3-phase, 50Hz
Control Circuit:	220 VAC, 1-phase, 50Hz	220 VAC, 1-phase, 50Hz	220 VAC, 1-phase, 50Hz
SWRO Skid			
Height:	224 cm (88")	224 cm (88")	224 cm (88")
Width:	132 cm (52")	132 cm (52")	132 cm (52")
Depth:	506 cm (199")	506 cm (199")	506 cm (199")
Weight Estimate for Shipping Purposes:	1542 kg (3400 lb)	1814 kg (4000 lb)	2041 kg (4500 lb)